

Falcons Eindhoven 2024 Qualification Materials

Table of Contents

Team Description Paper.....	2
1. Introduction	2
2. Bottom Mechanics with Drive Motors & Wheels	3
3. Ball Handlers	3
4. Kicker Module	4
5. Middle Mechanics with Electronics	4
6. Computer Box	5
7. Top Module with Cameras.....	5
8. Conclusion.....	6
List of Results and Awards In Last Three Years.....	6
1. RoboCup World Championship 2023 - Bordeaux, France	6
2. RoboCup World Championship 2022 - Bangkok, Thailand	6
3. RoboCup World Championship 2019 - Sydney, Australia.....	6
4. Portuguese Robotics Open 2019 - Porto, Portugal.....	6
List of Team Contributions to the MSL Community.....	6
Miscellaneous	7
List of MAC Addresses Used by the Team	7
Development laptops:.....	7
Robot Dimensions.....	7

Team Description Paper

1. Introduction

Our middle-size league robot for RoboCup 2024, named V1 Platform, is a technological marvel designed for optimal performance on the playing field. With dimensions of 520x520x790mm and a weight of 38kg, the V1 Platform boasts stability, agility, and a comprehensive set of features.

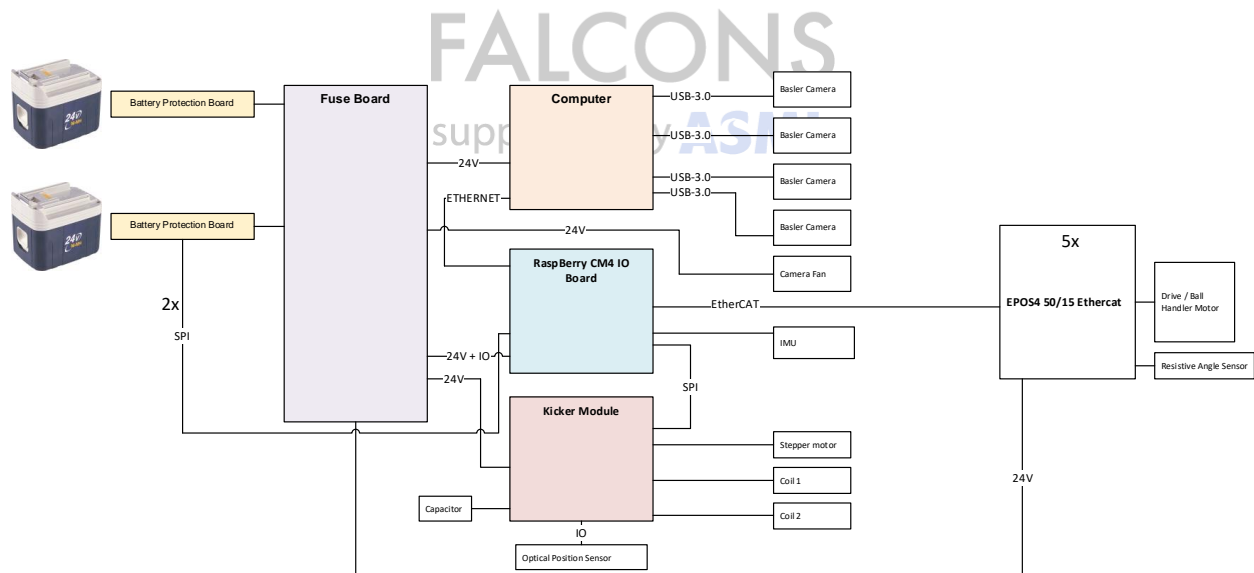
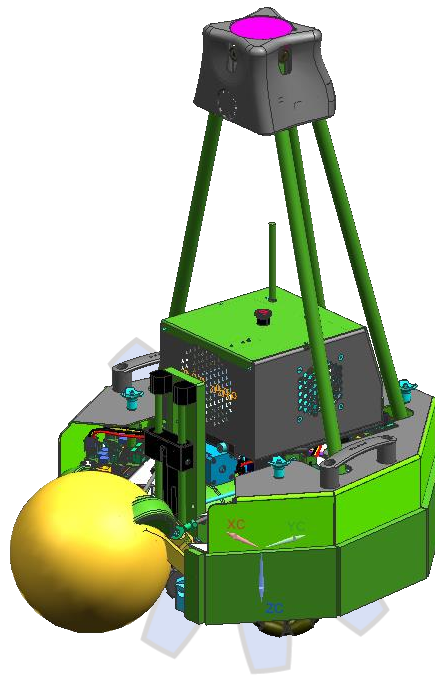

2. Bottom Mechanics with Drive Motors & Wheels

The robot's locomotion system utilizes Rotacaster 125mm triple wheels powered by Maxon EC90 400W Direct Drive Motors. The power source consists of a 24V 4.5Ah NiMh Battery with a dedicated Battery Protection Board. Additional components include a Shooting Capacitor (450V, 4.7mF), Kicker Module, and a robust bottom frame milled from 7000 series aluminum.

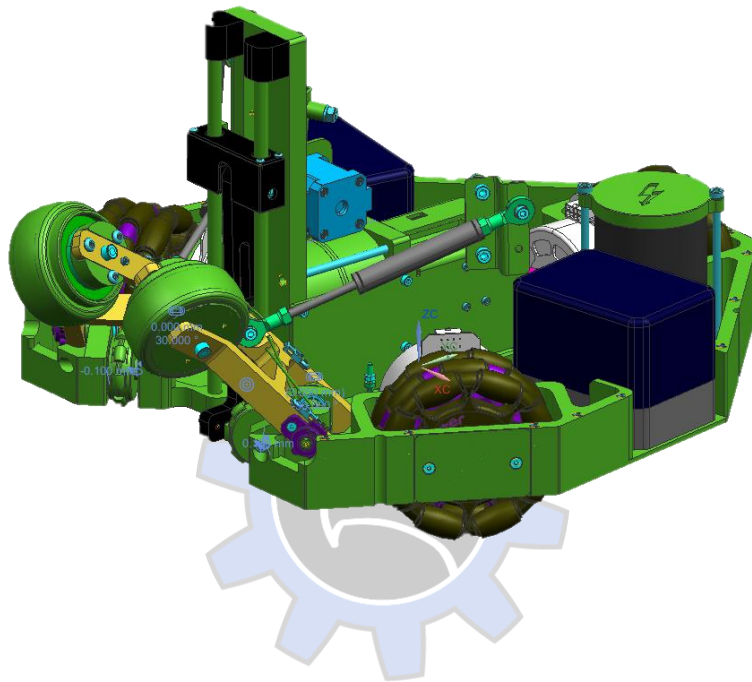

3. Ball Handlers

The V1 Platform excels in ball handling with a milled aluminum Ball Handler Arm, propelled by a Maxon EC60 Frameless 100W Direct Drive Motor. Precision and control are enhanced through the integration of a Hydraulic Damper, Return Spring, and a Resistive Angle Sensor.

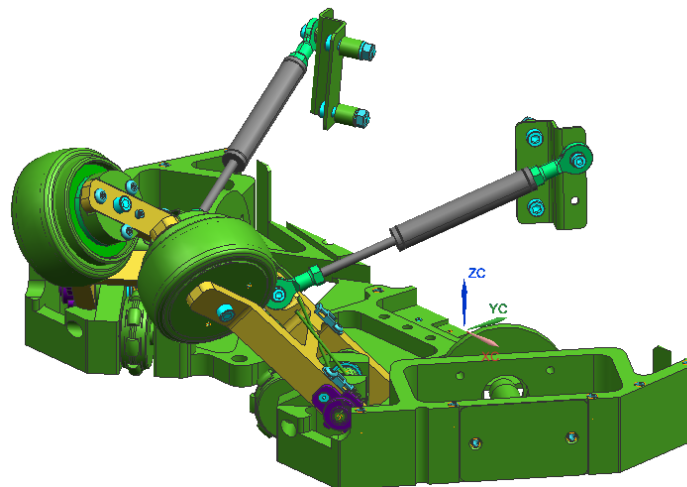

4. Kicker Module

The Kicker Module mirrors the Ball Handler's design, featuring a milled aluminum arm powered by a Maxon EC60 Frameless 100W Direct Drive Motor. The incorporation of a Hydraulic Damper, Return Spring, and Resistive Angle Sensor ensures a cohesive and effective kicking mechanism.

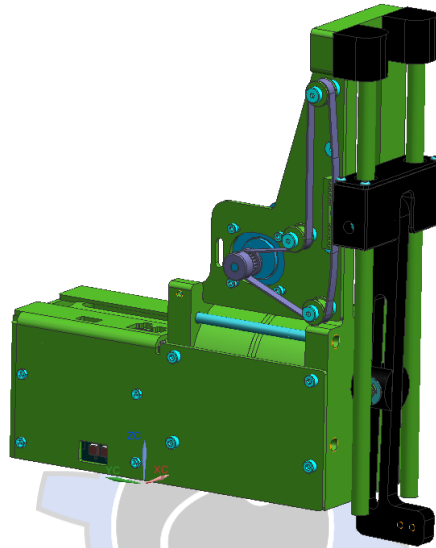

5. Middle Mechanics with Electronics

Central to the robot's functionality is the middle section, housing essential electronics on a 2mm aluminum Mounting Plate. This includes a Fuse Board, Raspberry CM4 IO Board, and five Maxon EPOS4 50/15 Ethercat controllers, forming a centralized and efficient control system.

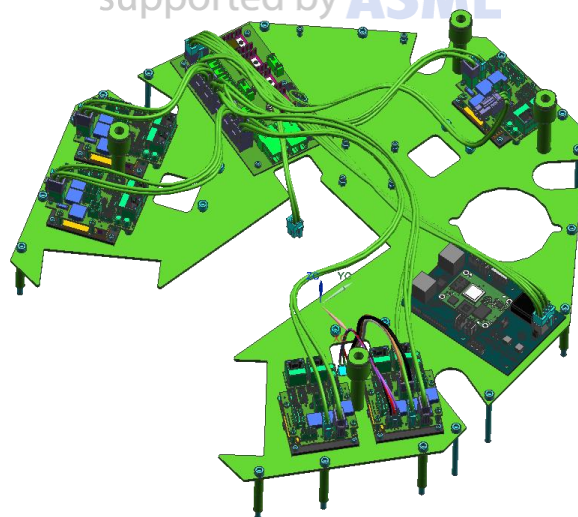

6. Computer Box

The custom-designed Computer Box serves as the robot's brain, enclosed in a robust casing. It features a DC-DC converter (0-60V to 12V) with an LCD for monitoring and control. The core comprises an ITX Motherboard with an Intel I5 13600 processor, coupled with a GeForce RTX3060 for advanced computational capabilities. Dual WIFI antennas ensure robust communication, and an Emergency Off Button provides a secure shutdown option.

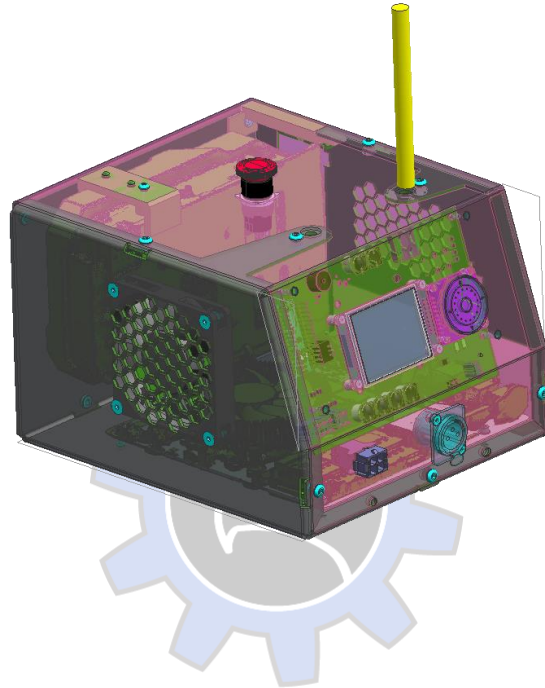

7. Top Module with Cameras

The top module is equipped with 3D-printed holders, carbon fiber tubes, and a 3D-printed hood to house and protect components. It accommodates a Basler Dart 54um Camera with USB-C connectivity, ensuring high-resolution vision for effective gameplay analysis. A 40mm fan with an inner frame contributes to temperature control, enhancing the reliability of the top module.

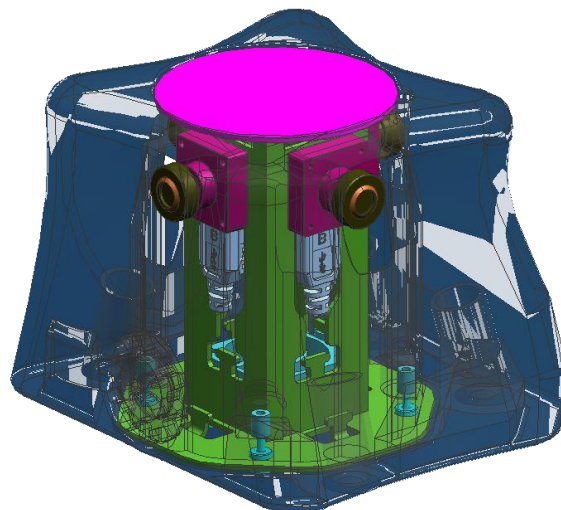

8. Conclusion

In conclusion, the V1 Platform is a meticulously designed robot that seamlessly integrates mechanical and electronic components. With its robust construction and advanced features, it stands as a formidable contender in the RoboCup 2024 middle-size league, poised to deliver outstanding performance on the playing field.

List of Results and Awards in Last Three Years

1. RoboCup World Championship 2023- Bordeaux, France

Tournament: 2nd

Scientific Challenge: 2nd

Technical Challenge: 1st

2. RoboCup World Championship 2022- Bangkok, Thailand

Tournament: 2nd

Scientific Challenge: 6th

Technical Challenge: 3rd

3. RoboCup World Championship 2019- Sydney, Australia

Tournament: 3rd

Scientific Challenge: 4th

Technical Challenge: 3rd

4. Portuguese Robotics Open 2019- Porto, Portugal

Tournament: 3rd



List of Team Contributions to the MSL Community

- Co-Host MSL Workshop together with VDL RobotSports (2023)
- Member of MSL Technical committee, E. Schreuder (2018 - 2021)
- Member of organization committee MSL Robocup Montreal, E. Schreuder (2018)
- Sharing field with Tech United & VDL RobotSports & RIF (Fontys Eindhoven) for development and local tournaments (2015-present)
- Referee semifinals/finals during World Championship Leipzig (2016)
- Co-Host MSL Workshop together with Tech United and VDL RobotSports (2014 / 2017)
- Co-chair Robocup European Open 2016, R.J.E. Merry (2016)
- Contributed to the Refbox interface and MSL rules (2016)
- Chair Robocup 2013, R.J.E. Merry (2013)

Miscellaneous

- Declaration of mixed teams: Yes
- Team requires 802.11b access point: No

List of MAC Addresses Used by the Team

Robots (needs update with new robots):

Hostname	MAC (wireless)	MAC (ethernet)
r1	00:16:6f:f7:f6:20	d0:50:99:af:71:1c
r2	00:16:6f:f7:f1:7a	70:85:c2:10:23:d4
r3	00:16:6f:f7:f1:d4	70:85:c2:10:23:63
r4	00:16:6f:f7:f0:e4	70:85:c2:10:22:ae
r5	00:16:6f:f7:f8:23	70:85:c2:10:24:8e
r6	00:16:6f:f7:f1:1b	d0:50:99:af:70:da

Development laptops:

The internal member selection procedure has not been finished yet. Therefore this list cannot be provided now. The list will be completed in due time.

Developer	Hostname	MAC (wireless)	MAC (ethernet)
	Coach	60:67:20:00:5c:54	b4:b5:2f:31:6a:5e

Robot Dimensions

- Length: 45cm
- Width: 45cm
- Weight: 37.8 kg

